

CHASSIS PREPARATION

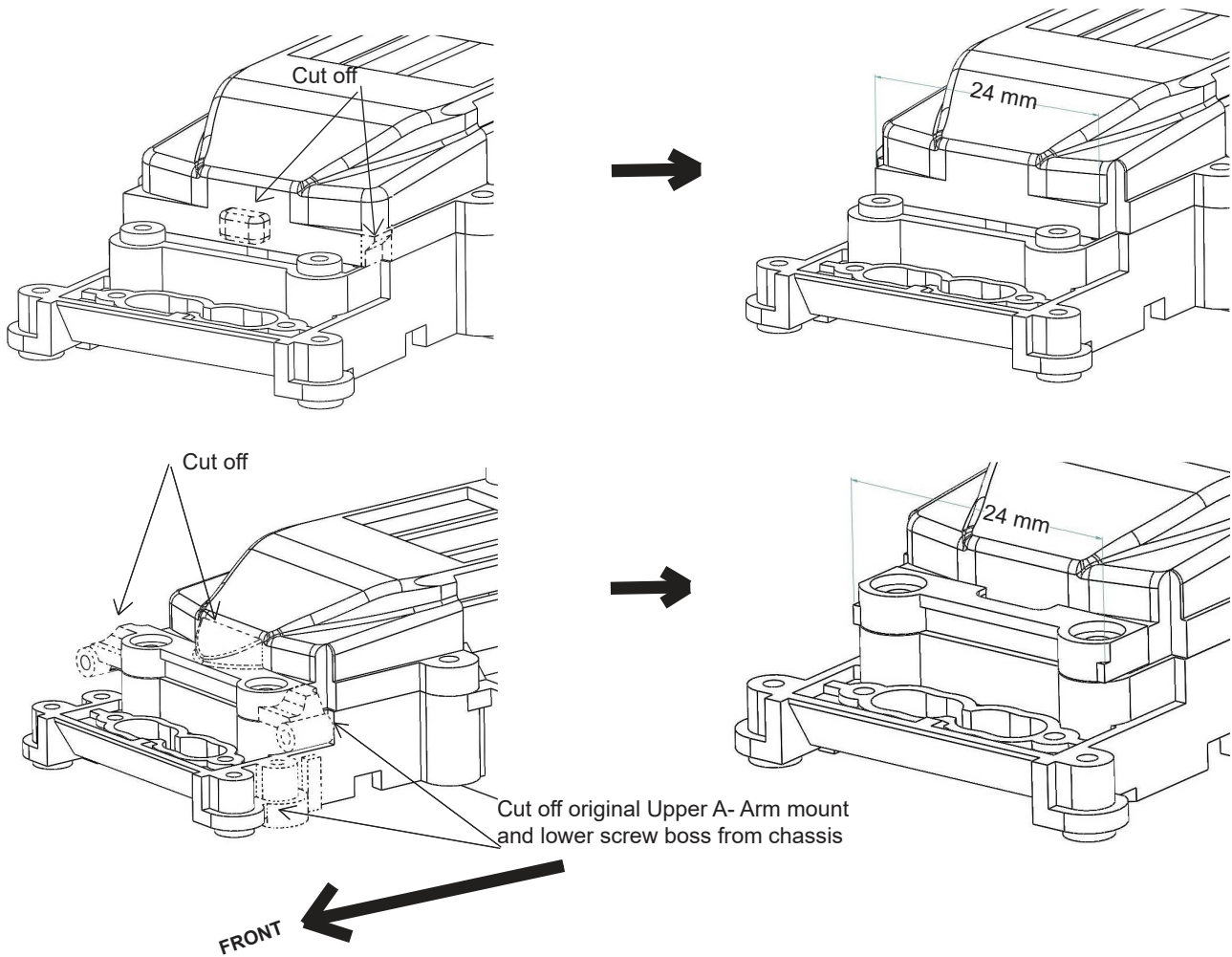

V-LINE NARROW SUSPENSION SYSTEM INSTALL

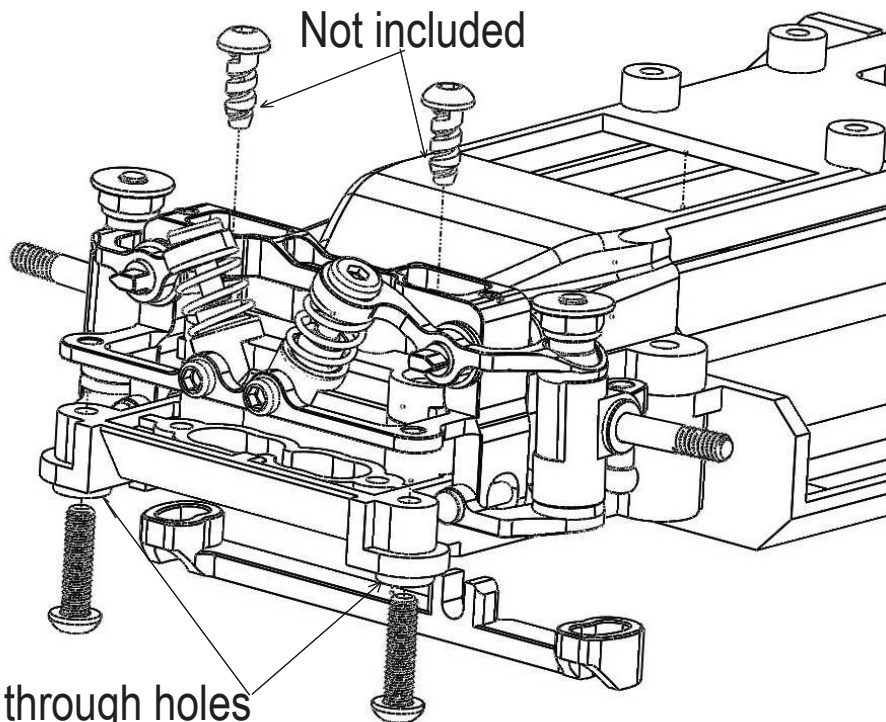

Slide the V-line Narrow Suspension system into original upper A-arm holes position then tighten 4 mounting screws to seat the V-line on chassis

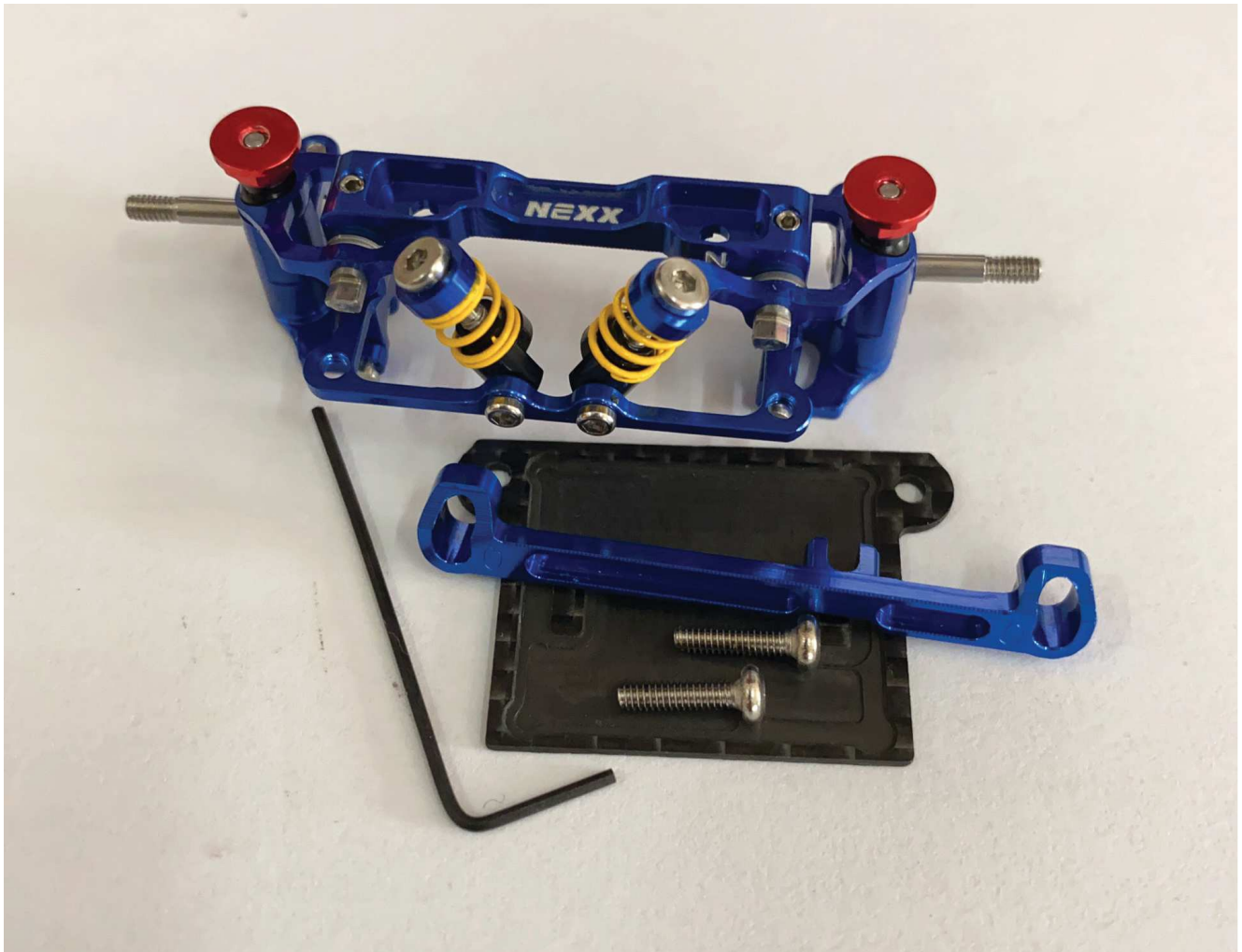

V-Line Narrow front suspension system : 1 pc
Toe tie rods : 1 pc (0°)
Button head M2x8 : 2 pcs
Carbon plate cover : 1 pc
Hex key 0.9 mm: 1 pc

CAMPER ADJUSTMENT

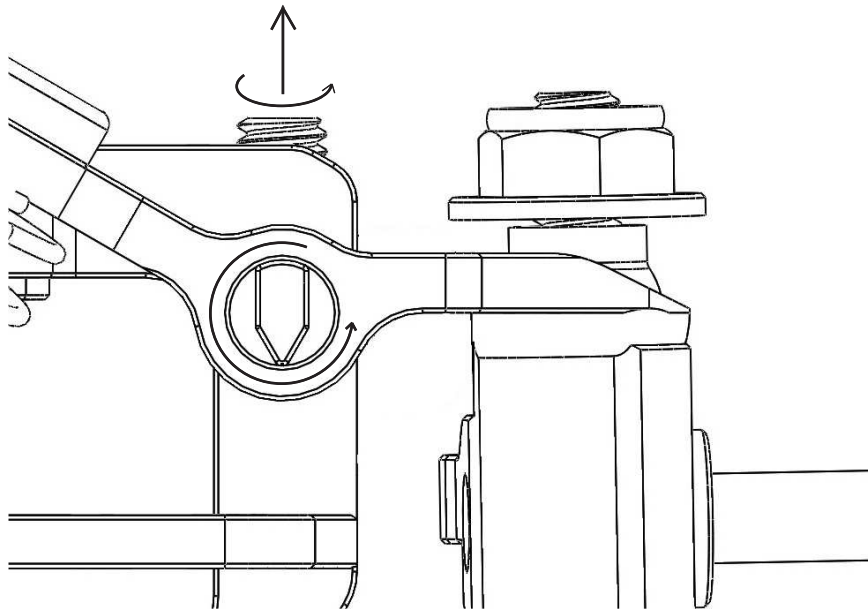

Loosen the flat point screw then rotate shaft 90° 180° 270° corresponding to the static camper which you choose

Left

Right

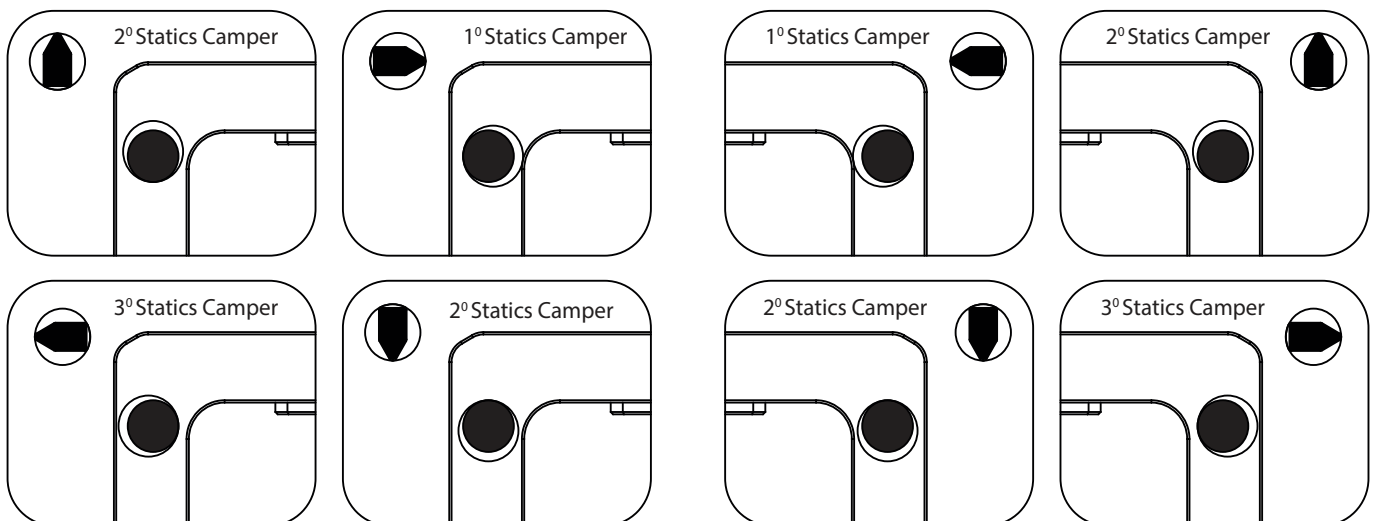

1 degree Lower Arm installed

CASTER ADJUSTMENT

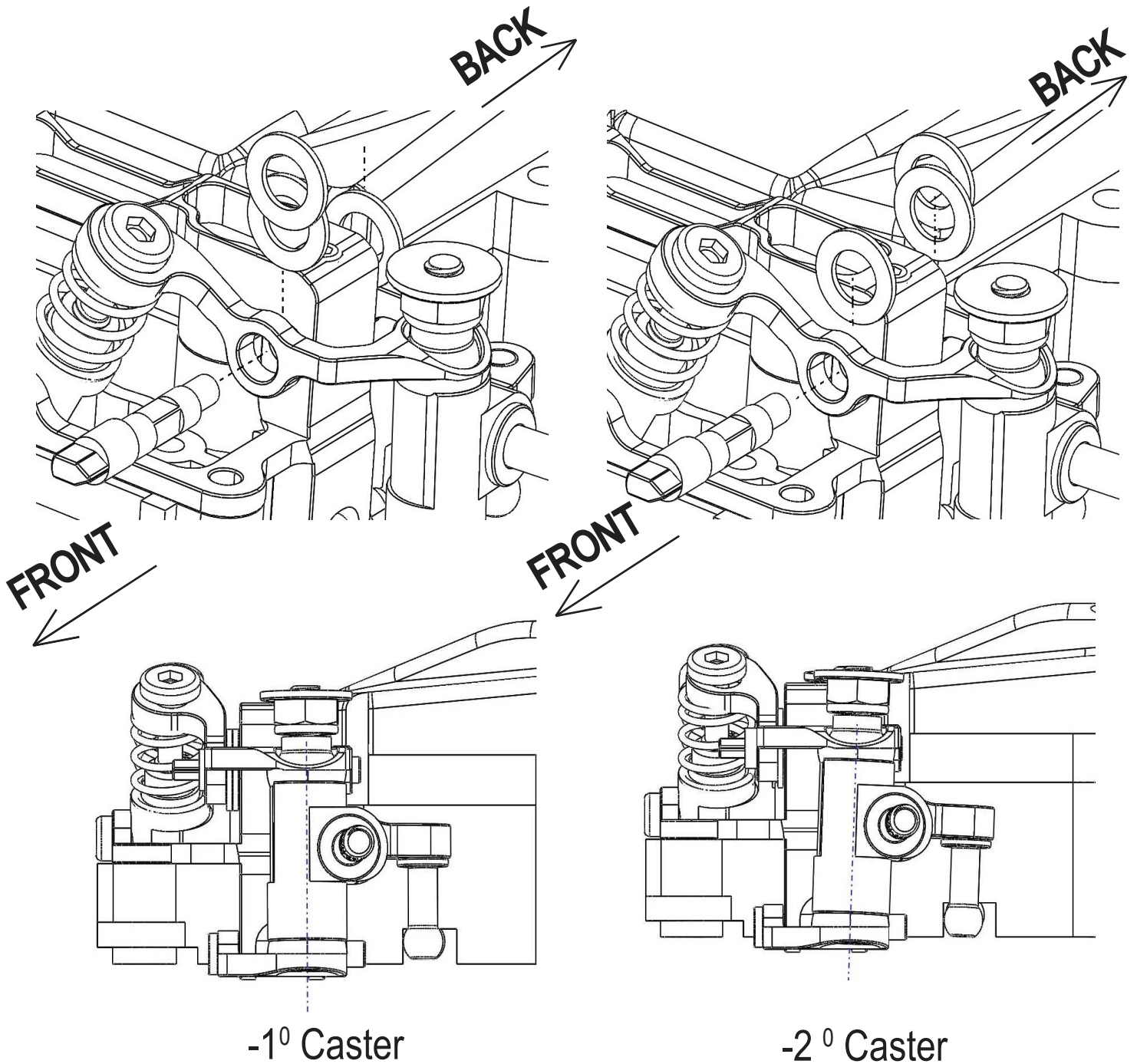

Loosen the Phillip screw then move cam shaft forward (FRONT) and fill two wahser in to the gap bettween Upper Arm and Bracket (FRONT) , one washer in to the gap bettween Upper Arm and Braket (Back) have (-1 ° Caster) fill one wahser in to the gap bettween Upper Arm and Bracket (FRONT) , two washer in to the gap bettween Upper Arm and Braket (Back) have (-2 ° Caster)

REMOVE AND INSTALL SPRING

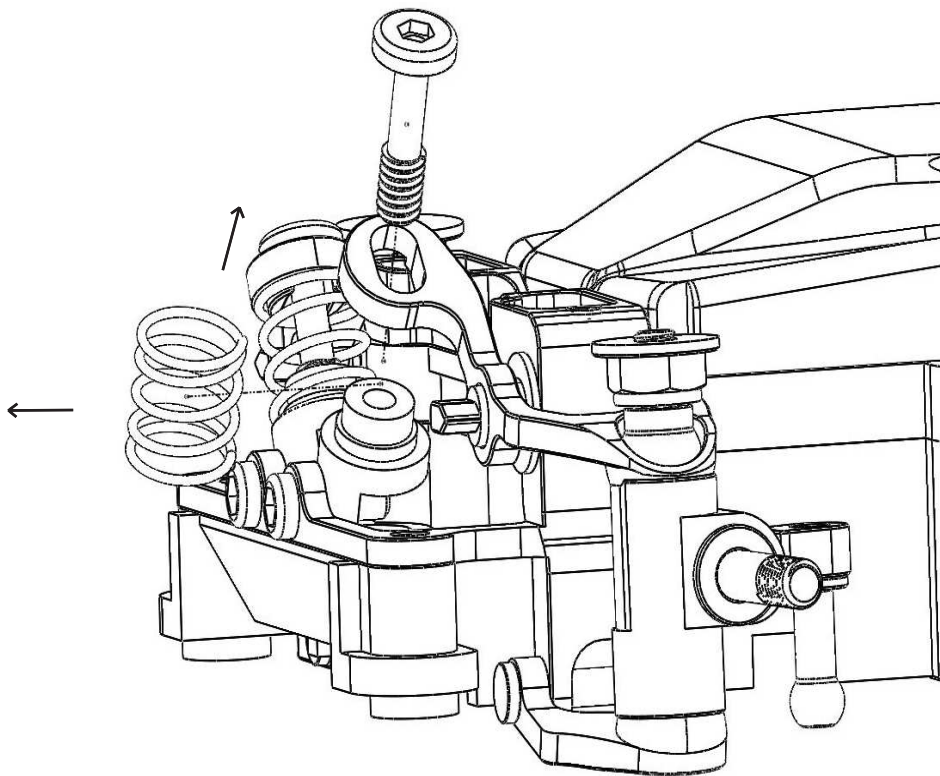
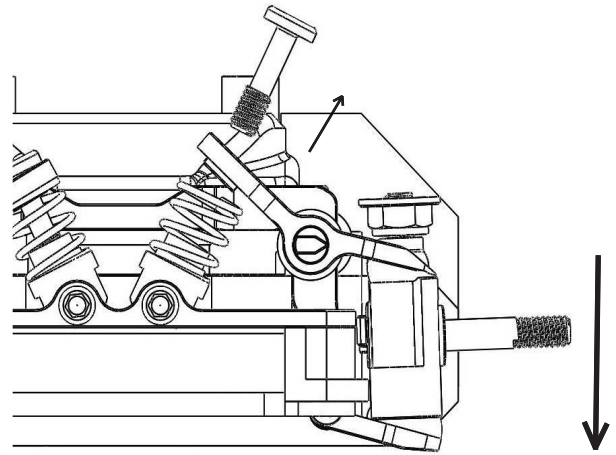
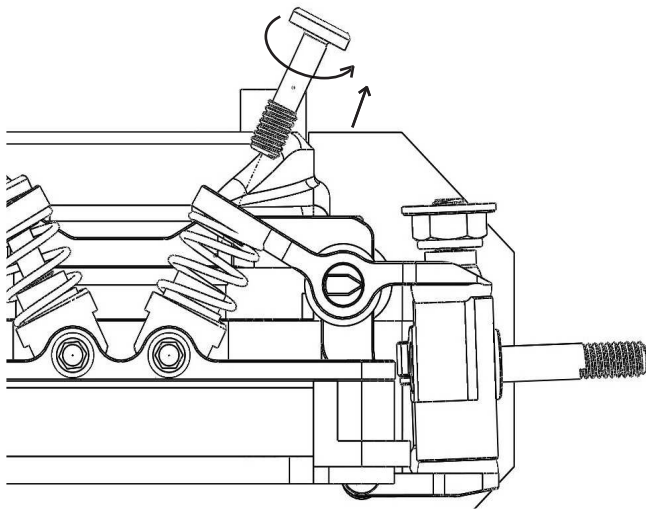

TIE ROD ADJUSTMENT

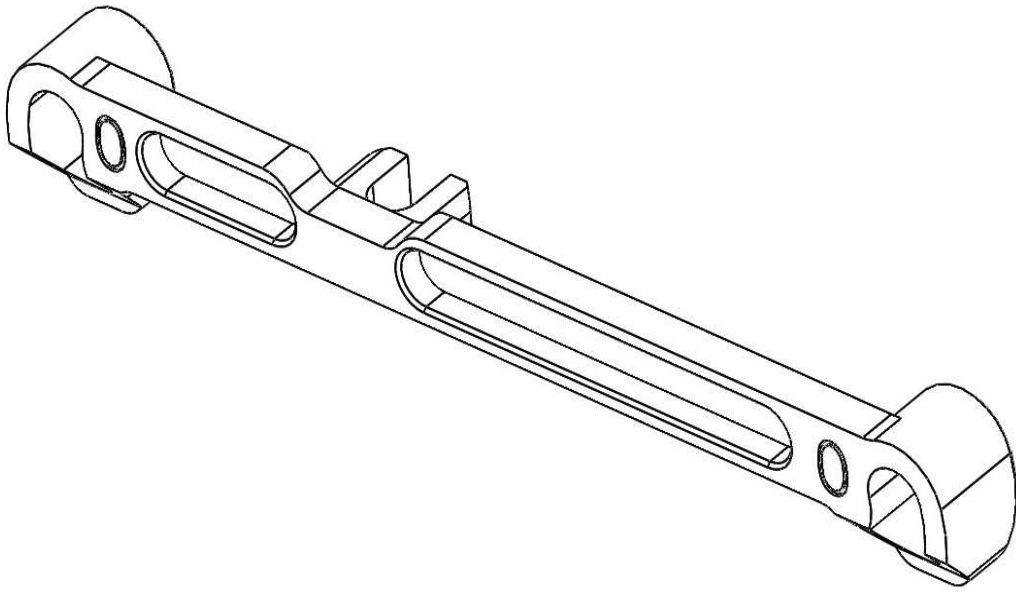

Included is 0° tie rod